

Fig.2

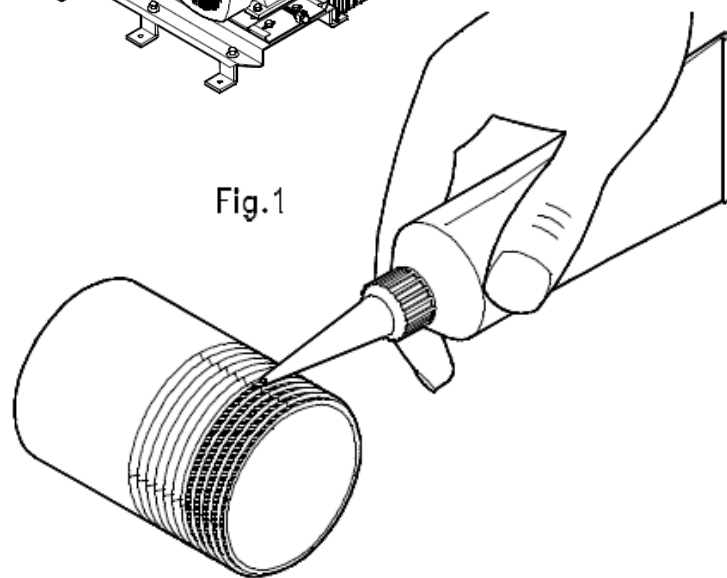

Fig.1

## To the installers of ENGLISH LANGUAGE

1) To avoid the dispersion of residues of the lubricating oil of the vacuum pump, - image 2 - we ask to the installer of:

- to install a tube B2 joined to the valve of exit V by a union elbow B1,
- to put a drain tank B3 under the tube B2,
- to insert the flexible tubes A1 and A2 in a drain tank A3,
- to make a hole of bleed F on both the tanks.

2) The defective tightness of the threaded junctions of the group separator-silencer is source of drippings of lubricating oil with consequent formation of anaesthetic and ant hygienic sludges.

To avoid losses we ask to the installer to apply a motor silicone gasket - fig. 1:

- on the threaded junctions of the group separator-silencer - image 2, pos. from 1 to 7,
- on the threads of the nipples of recovery oil - image 2, pos. 8 and 9.

**Note:** exclusively to use plastic gaskets based on silicone. We suggest the following makers:

**Loctite 209079 Art.26807, Arexons Art.motorsil D,**

**Wurth Art.0893 260 100 - S, Angst + Pfister**